

10 Tighten screw B and the bottom of the double nut

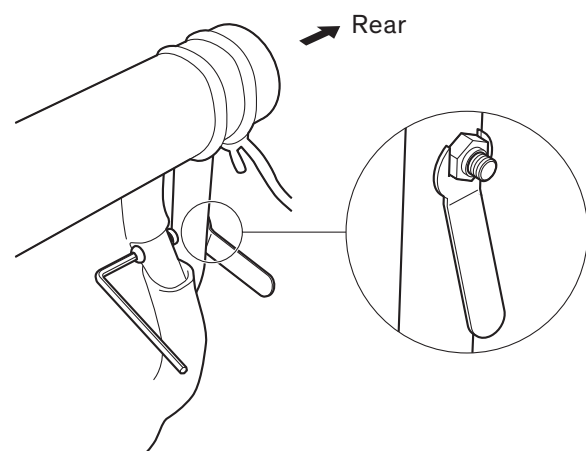

Using a screwdriver and the supplied allen wrench and spanner, tighten the pre-tightened screw and the bottom of the double nut until there is no gap.

11 Tighten the top of the double nut using the two spanners

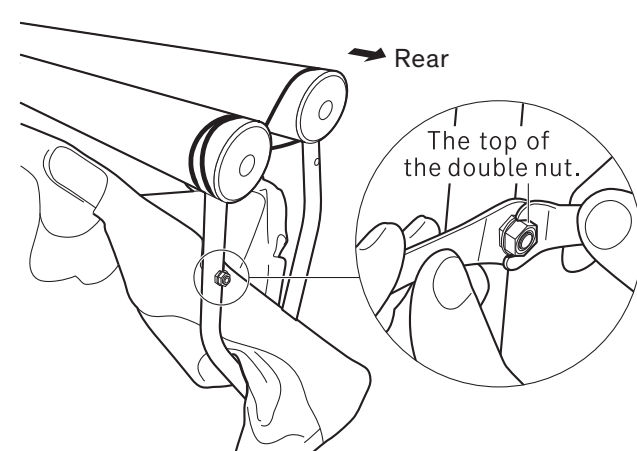

Hold the bottom of the double nut with a spanner so that it does not move, and turn the top of the double nut with another spanner to tighten it.
* Tighten until there is no gap between the nuts.

12 Secure the opposite side in the same way (see 6 -11), and when all the screws are tightened, open the chair, and tighten the screws to the end to complete this procedure

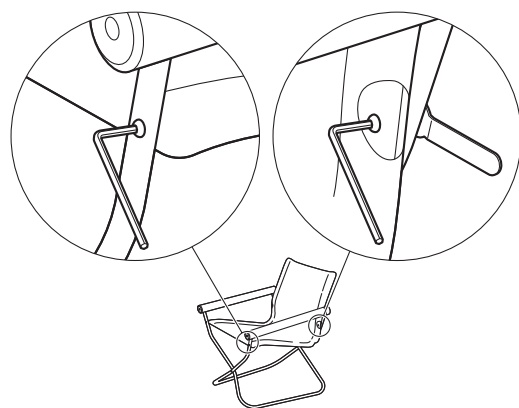

Nychair X™ 80

Seating Fabric Replacement Manual

Thank you for purchasing our product.
Check each part and component before replacing the chair seat, while following each instruction.
Keep this replacement manual after reading it.



Assembly Components

Check all components and the quantity of each component before assembly

<For the front>	<For the rear>	Diagram of chair assembly with labels: Seating fabric, Arm rest, Front, Rear, Double nut (top), Double nut (bottom), Screw A, Screw B, Spacer, Chair legs.		
<p>2 hexagon socket button head screws A *screw tip colored</p>	<p>2 hexagon socket button head screws B 2 spacers 2 Double nuts</p>	<p>Seating fabric</p>	<p>Accessory tool : 2 spanners</p>	<p>Accessory tool : Allen wrench</p>

2022.02

FUJIEI

Fujiei Corporation 1-2-2, Tairamachi, Meguro-ku, TOKYO, 152-0032, JAPAN
www.fujiei.co.jp

Official WEB SITE
www.nychairx.jp



READ THESE INSTRUCTIONS BEFORE ASSEMBLY

- ※Do not use any electrical tools.
- ※Ensure an enough space for assembly, and lay something to protect the floor surface.

■ Replacement Procedure

1 Remove screws

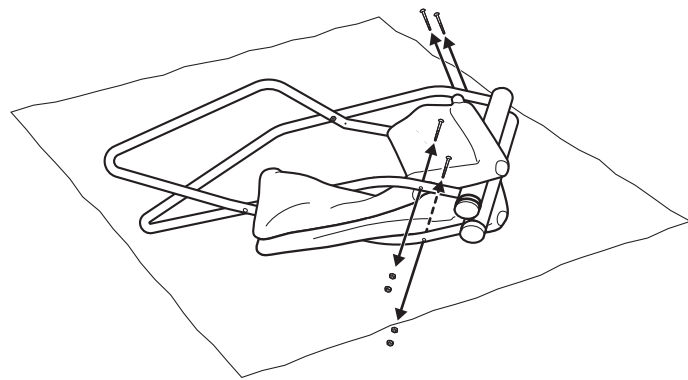

Work with a rug on the floor and lay the body of the chair. Remove screws from the body and disassemble the seating fabric and body.

2 Pull out the seat pipes

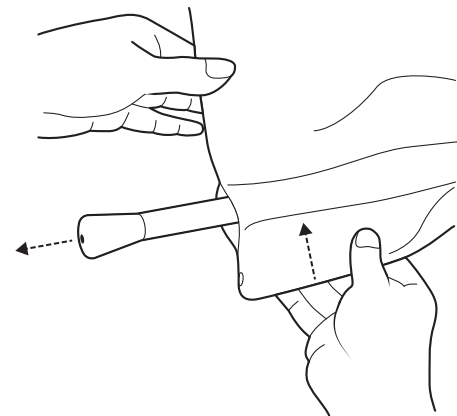

Pull out the seat pipes from the seating fabric.

3 Insert the seat pipes into the new seating fabric

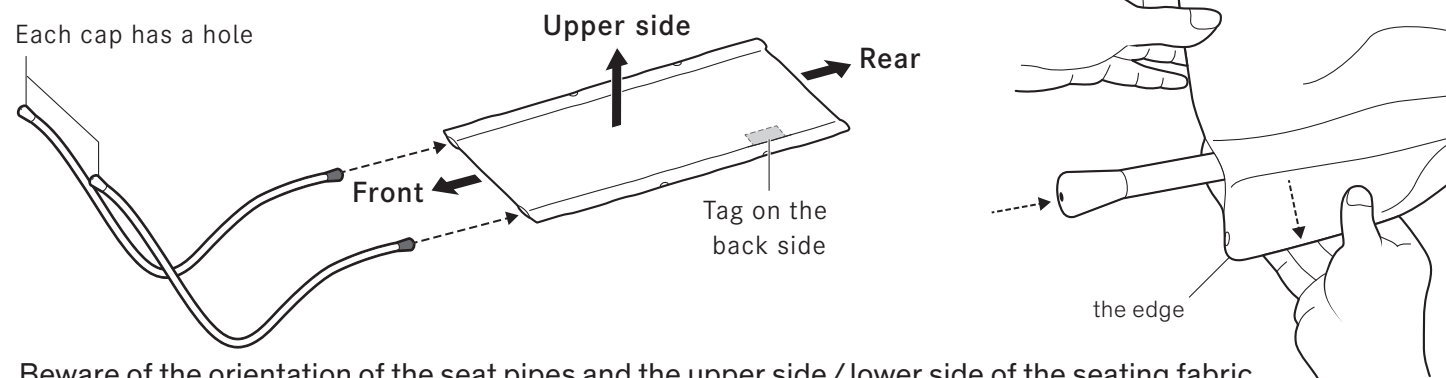

Beware of the orientation of the seat pipes and the upper side / lower side of the seating fabric. (Make sure that the tag and the care label are on the lower side of seating fabric.) Push the seat pipes firmly into the seating fabric, and at last place the edge of the seating fabric over the seat pipes. (The seat pipes are completely hidden.)

4 Rotate the seat pipes fitted with the seating fabric to the folded state

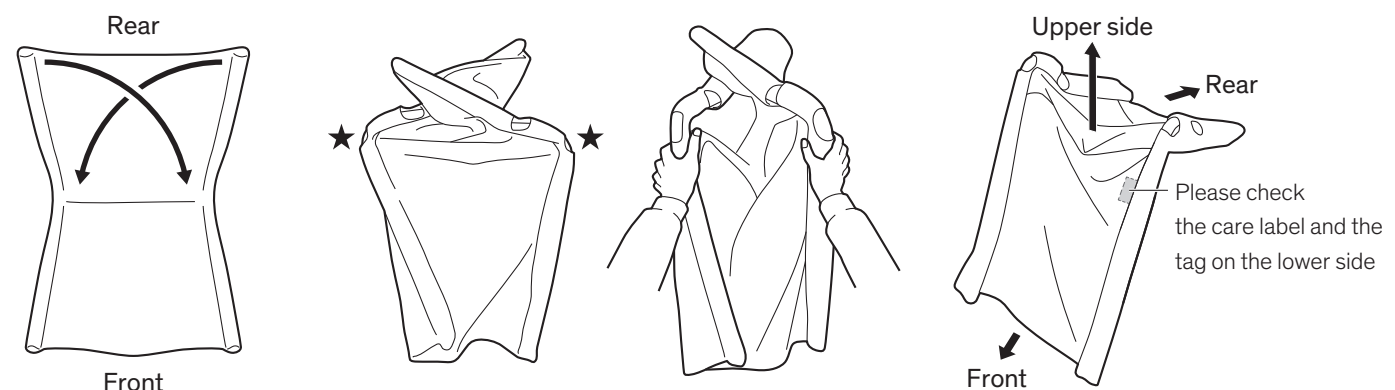

Tilt the right and left seat pipes inwardly.

Lift the seat pipes ★ section upwardly.

Set the seat pipes so that the upper side of the seating fabric is on the top.

5 Place the seat set in 4 on the foot section X

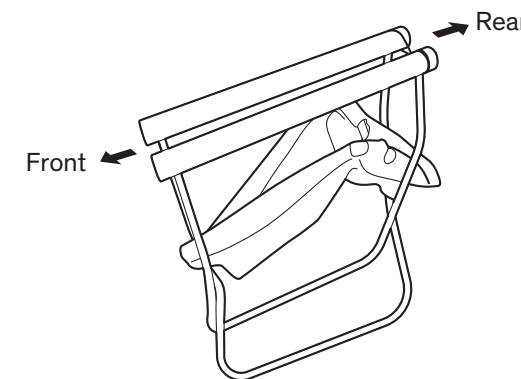

Position the seat so that the rear seating fabric is on the higher arm and the front seating fabric is on the lower arm.

6 Place screw B and a spacer on the rear seat pipe

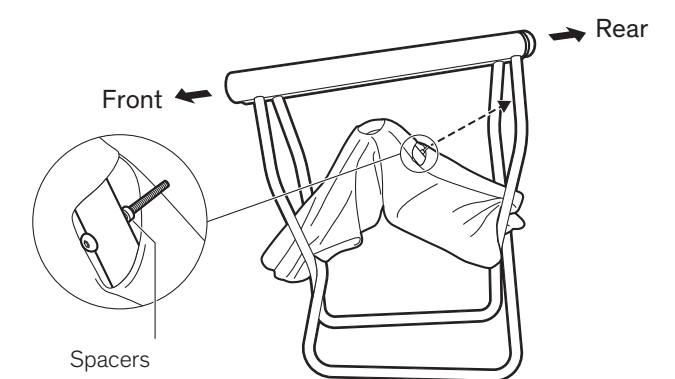

Pass the screw through the seat pipe before attaching the spacer.

7 Pass the screw B which is fitted with the spacer in 6 through the rear leg, and pre-tighten the bottom of the double nut

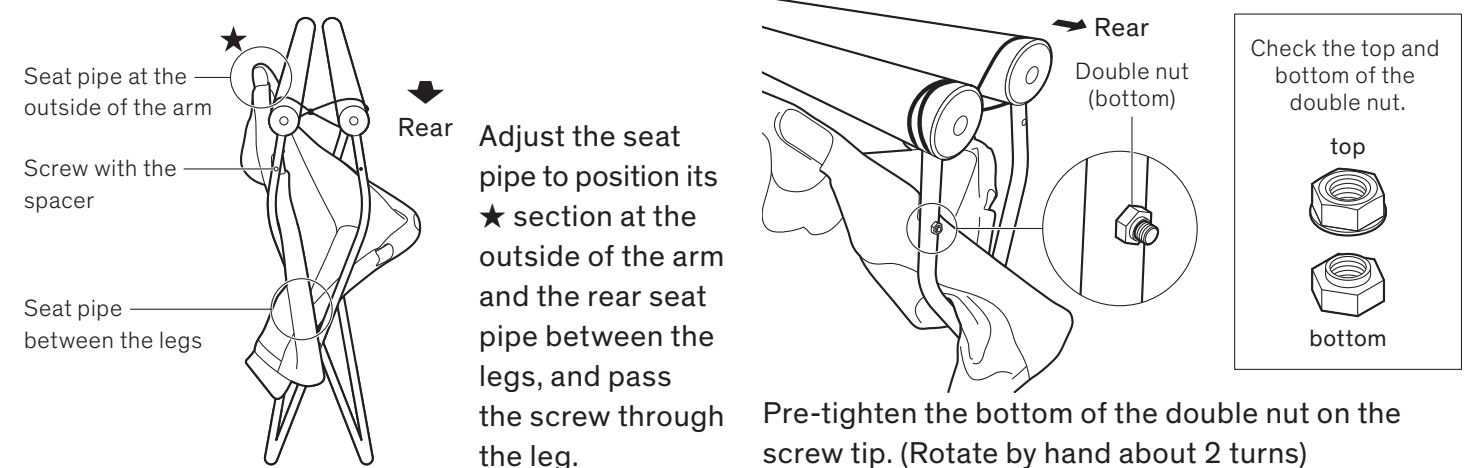

Adjust the seat pipe to position its ★ section at the outside of the arm and the rear seat pipe between the legs, and pass the screw through the leg.

Pre-tighten the bottom of the double nut on the screw tip. (Rotate by hand about 2 turns)

8 Widen the hole on the front of seating fabric to facilitate insertion of a screw

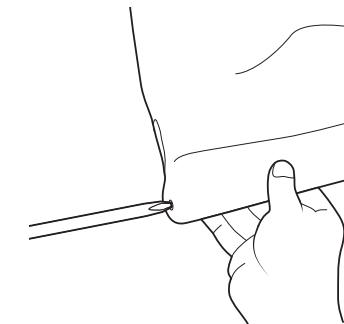

There is a hole on the front of the seating fabric for attaching a screw. Use a Allen wrench or similar method to spread the hole where the screw is inserted.

9 From the front leg, pass screw A through the seat pipe (the cap with a hole) and tighten it with a allen wrench

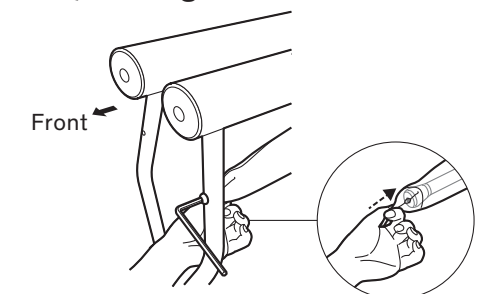

While holding the seating fabric, pass the screw through the seat pipe and tighten it with a allen wrench, so that the seat pipe is positioned on the edge of the seating fabric.

*If it is hard to insert the screw, do not force it but check the orientation of the screw.