

Nychair X™ Nychair X™ Rocking

Seating fabric Replacement Manual

Thank you for purchasing our products.
Follow the procedures on this manual when replacing the chair sheet.
Keep this manual after reading it.

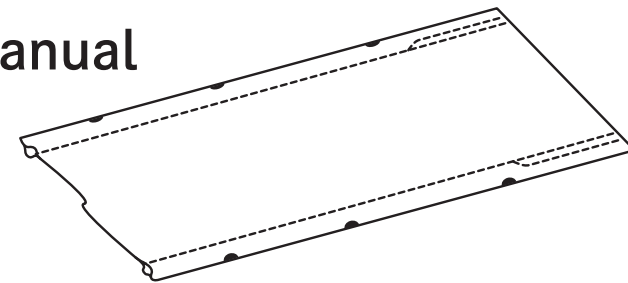

■ Replacement Procedure (for Nychair X and Nychair X Rocking)



READ THESE INSTRUCTIONS BEFORE ASSEMBLY

CAUTION

- *Prepare a Philips-head screw driver before assembly.
- *Do not use any electrical tools.
- *Ensure enough space for assembly, and lay something to protect the floor surface.

1 Remove all screws

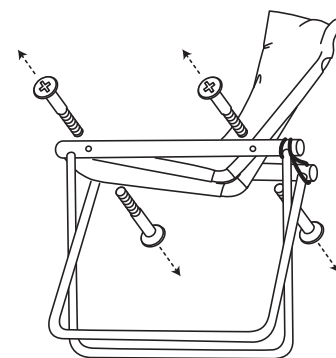

Remove all screws from the chair, and disassemble the seating fabric and the chair itself.

2 Take the pipes out

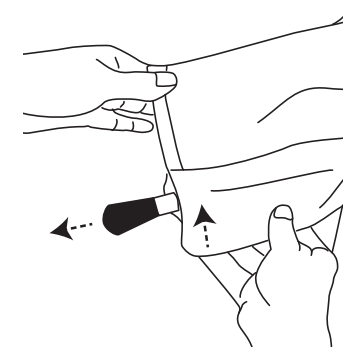

Take the pipes out of the seating fabric.

3 Insert pipes into the new seating fabric

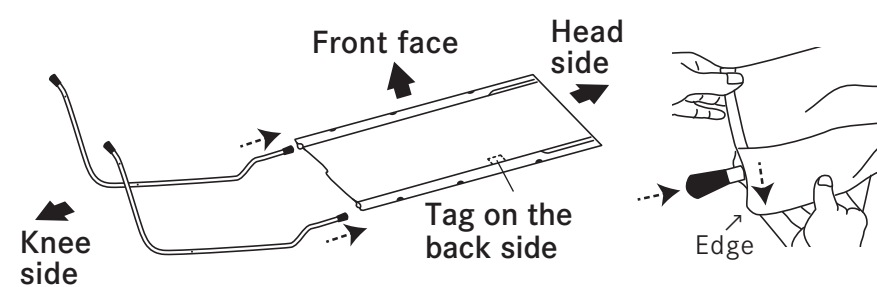

Insert the pipe into each pipe hole of the new seating fabric in the direction shown above.
*Be aware of the pipe direction and the front/back side of the seating fabric. There is a tag on the back side of the seating fabric.
*Push in each pipe fully, and then cover the pipe end with the seating fabric edge.

4 Fix each chair component with screws

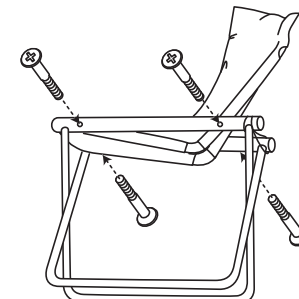

Assemble the chair legs and the new seating fabric with the pipes inserted by using the screws.
*Refer to the Assembly and Instruction Manual for the assembly of the chair.

2015.06